

**University of Jordan
School of Engineering
Electrical Engineering Department**

**EE 204
Electrical Engineering Lab**

**EXPERIMENT 10
HOME WIRING BASICS**

Prepared by: Prof. Mohammed Hawa

EXPERIMENT 10 HOME WIRING BASICS

OBJECTIVE

This experiment introduces some basic principles that everyone should know about residential wiring, lighting, electrical installation and safety.

PROCEDURE A - CONDUCTOR SIZES AND TYPES

The most popular type of conductors used in home wiring is the copper conductor. The copper wires used in electrical installations are manufactured to well-known standards so that people know the details of the wires they are buying. In the U.S., wires are built according to the *American Wire Gauge* (AWG) standard. The wire diameter in the AWG standard is expressed as a whole number. The higher the AWG number, the smaller the wire diameter, which reduces its current-carrying capacity (ampacity). Smaller diameter conductors have higher resistance, which means they heat up more at high current, thus melting the insulation and damaging the cable and also potentially resulting in short circuits. Some details are shown in Table 1 below.

Table 1.

Conductor Size	Typical Applications	Equivalent Area (mm ²)	Insulation Thickness (mm)	Approx. Overall Diameter (mm)
20 AWG	Telephone wiring is usually 20 or 22 AWG (5 Amperes)	0.518	0.30	2.0
18 AWG	Thermostats, chimes, security and home automation systems, etc.	0.823	0.38	2.4
16 AWG	Same applications as above. Good for long runs to minimize voltage drop (7 Amperes).	1.31	0.38	2.7
14 AWG ‡	Typical lighting branch circuits (15 Amperes) ‡	2.08	0.38	2.9
12 AWG ‡	Small-appliance branch circuits for the receptacles in kitchens and dining rooms (20 Amperes) ‡	3.31	0.38	3.4
10 AWG	Clothes dryers, built-in ovens, some central air conditioners, some water heaters (30 Amperes)	5.26	0.51	4.3
8 AWG	Electric Ranges, ovens, heat pumps, some large clothes dryers, large central air conditioners, heat pumps (40 Amperes)	8.37	0.76	5.6
3 AWG	Main service-entrance conductors, feeders to subpanels (100 Amperes)	26.65	2.3	8.4

‡ Students should expect to be asked about values designated by this marker in the final exam.

Here in Jordan, the conductors used for home wiring follow the International Electrotechnical Commission standard IEC 60227 and British standard BS 6004. Some of the most popular cables used for lighting and internal wiring are summarized in Table 2 with their current carrying capacity.

Table 2.

Type of Conductor*	Nominal Area (mm ²)	Insulation Thickness (mm)	Approx. Overall Diameter (mm)	Current carrying capacity (Ampere)**
Solid	0.5	0.6	2.0	2.7
	0.75	0.6	2.2	5.4
	1.0	0.6	2.4	9.0
	1.5 †	0.7	2.8	14.4 †
	2.5 †	0.8	3.4	22.5 †
	4	0.8	3.9	33.0
	6	0.8	4.4	43.0
	10	1.0	5.6	60.0
Stranded	0.5	0.6	2.2	2.7
	0.75	0.6	2.4	5.4
	1.0	0.6	2.6	9.0
	1.5 †	0.7	3.0	14.4 †
	2.5 †	0.8	3.6	22.5 †
	4	0.8	4.2	33.0
	6	0.8	4.7	43.0
	10	1.0	6.1	60.0

* Insulation: PVC Insulation type TI1 as per BS EN 50363, PVC/C as per IEC 60227 temperature rating 70° C.

** Single-phase AC current in RMS depends on installation conditions (such as if cables are laid in ducts or underground, ventilation, temperature, etc).

† Students should expect to be asked about values designated by this marker in the final exam.

A wire may be a single strand (solid conductor), or it may consist of many strands (see Figure 1). Each strand of wire acts as a separate conducting unit. The wire size used for a circuit depends on the maximum current to be carried.



Figure 1. Solid, stranded and flexible copper wires.

1. You will be provided with three wires that are used in residential wiring. Measure both the diameter of the inner copper conductor and the outer overall diameter of the wire. Record this information in Table 3. Use the inner copper conductor diameter to evaluate the cross sectional area of each wire, then use Tables 1 and 2 above to decide the maximum current these wires are designed to carry.

Table 3

	Wire 1	Wire 2	Wire 3
Copper diameter (mm)			
Copper cross sectional area ($A = \pi r^2$) (mm²)			
Wire outer diameter (mm)			
Wire current capacity (A)			
Wire color			

2. What are the two most popular wire sizes used in residential wiring in Jordan? Ask if you do not know.

.....

3. Another type of cable you will be provided with in the Lab is used for Ethernet networks. Describe the cable (each wire diameter, number of wires in the cable, colors, etc).

.....





4. What is the name of the connector attached to the Ethernet cable described above?

.....

PROCEDURE B - LUMINAIRES AND LAMPS

A luminaire is a “lighting fixture” consisting of a light source such as a lamp, together with the parts designed to position the light source and connect it to the power supply. Table 4 provides a comparison of the most popular lamps available nowadays and their typical characteristics.

Table 4

Type of Lamp ‡	Lumen per Watt ‡	Typical Power Rating‡	Color and Application	Life (approx. hours)
Incandescent 	14–18	60W, 75W, 100W	Warm and natural. Useful for general lighting.	500, 750, 1000, 1500, 3000 hours. Depends on type of lamp. Lamp life typically is based on operating the lamp an average of 3 hours of operation per start.
Halogen 	16–22	77 W	Brilliant white. Used for accent and task lighting. Similar to conventional incandescent lamps, but more efficient because they are filled with a Halogen gas, such as iodine, allowing the filament to run hotter (whiter).	2000 to 4000 hours. Lamp life typically is based on operating the lamp an average of 3 hours of operation per start.
Fluorescent 	82-104	14 W, 21W, 28 W	Warm and warm white, cool and cool white, plus many other shades of white. Used for general lighting. The higher the K rating, the cooler (whiter) the color rendition.	6000 to 24,000 hours. Average life with lamps turned off and restarted once every 12 operating hours.
Compact Fluorescent Lamp (CFL) 	46-75	11 W, 14 W, 18 W, 24 W	Soft warm white. Uses about 80% less energy, and generates 90% less heat than equivalent incandescent lamp.	10,000 to 15,000 hours. Can last 9 to 13 times longer than incandescent. Lamp life typically is based on operating the lamp an average of 3 hours of operation per start.
Light-Emitting Diodes (LEDs) 	50-123	8 W, 10 W	Bright white and soft white. Excellent color rendition. Applications range from flashlights to home, office, and parking lot area lighting. Contains a cluster (array) of many individual LEDs to produce high lumens.	25,000 to 100,000 hours.

‡ Students should expect to be asked in the final exam about values in the columns of this table that are designated by this marker.

Figure 2 illustrates how to wire a fluorescent light tube. A fluorescent lamp contains mercury-vapor gas inside the tube (A). Heating the two filaments (F) at each end of the fluorescent tube produces enough electrons around them. If a high voltage (in the range of a thousand volts) is applied across the lamp (i.e., between the two filaments), the gas gets ionized creating an arc within the tube, which excites the mercury vapor causing it to produce ultraviolet light that then causes a phosphor coating on the inside of the bulb to glow.

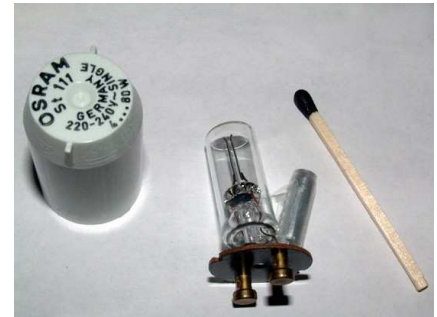
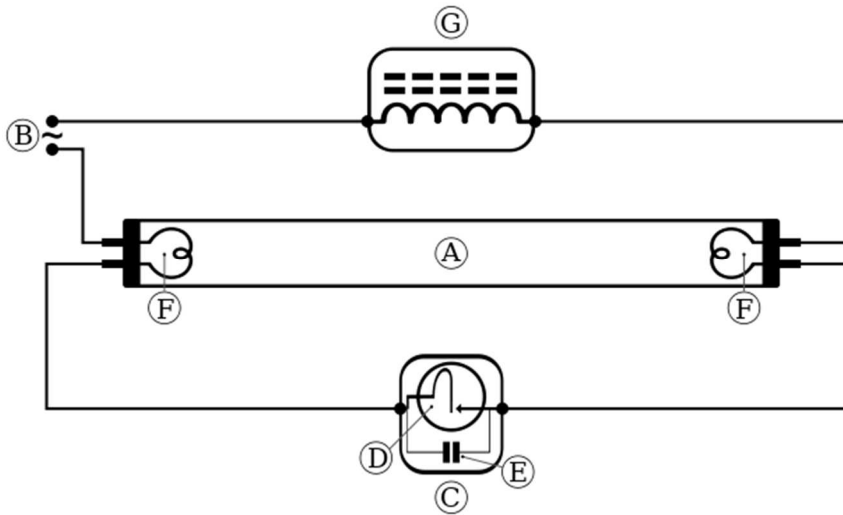
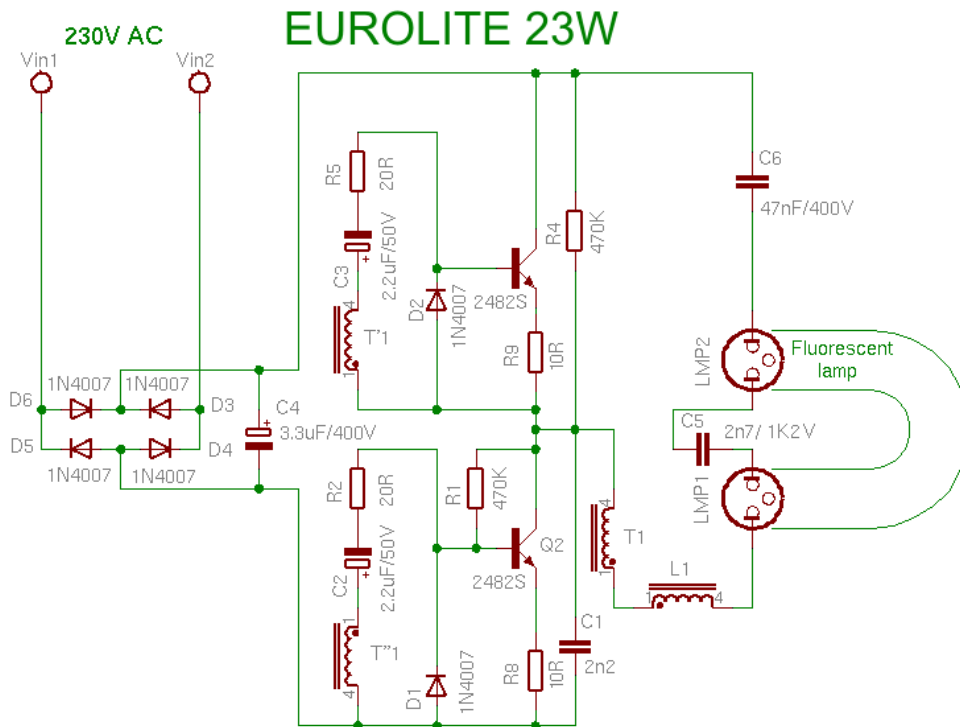

Figure 2.

To create this high voltage, fluorescent lamps require the combination of a ballast (G) and bi-metallic switch, known as a starter (D), to work. When AC power is first turned on, there will be a glow discharge across the electrodes in the starter, allowing it to pass electric current that heats up the filaments inside the tube enough for them to emit electrons (thermionic emission), but no arc will exist. However, in the starter, the gas cools down and no longer heats the bi-metallic switch, which opens within a second or two. This means the current through the filaments and the inductive ballast is abruptly interrupted, creating a very high voltage (remember that $v = Ldi/dt$) which is applied between the filaments at the ends of the tube. This is called an inductive kick and it creates the arc between the filaments thus producing light in the lamp. The lamp will fail to strike if the filaments are not hot enough, in which case the cycle repeats; several cycles are usually needed, which causes flickering and clicking during starting. A power factor correction capacitor (E) usually draws leading current from the mains to compensate for the lagging current drawn by the lamp circuit.

Without a ballast, the lamp would probably not start. But if it did start, it would present almost zero impedance to the mains voltage, thus increasing the current flowing through the gases within the lamp, destroying the lamp in a very short time. The ballast acts as a high impedance to limit the current after starting.

Compact Fluorescent Lamps (CFLs) use similar principles as the fluorescent tubes, but usually run on electronic ballasts, which typically employ transistors to change the supply frequency into high-frequency AC while also regulating the current flow in the lamp. Electronic ballasts are commonly supplied with AC power, which is internally converted to DC and then back to a variable frequency AC waveform. A schematic of an electronic ballast is shown in the following Figure.



LED lights do not need ballasts, but they need an electronic LED driver, which converts the AC power into DC power, and also regulates the electric current drawn by the LED. Some LED drivers can also provide additional features such as dimming and control. An example LED driver circuit is shown below.

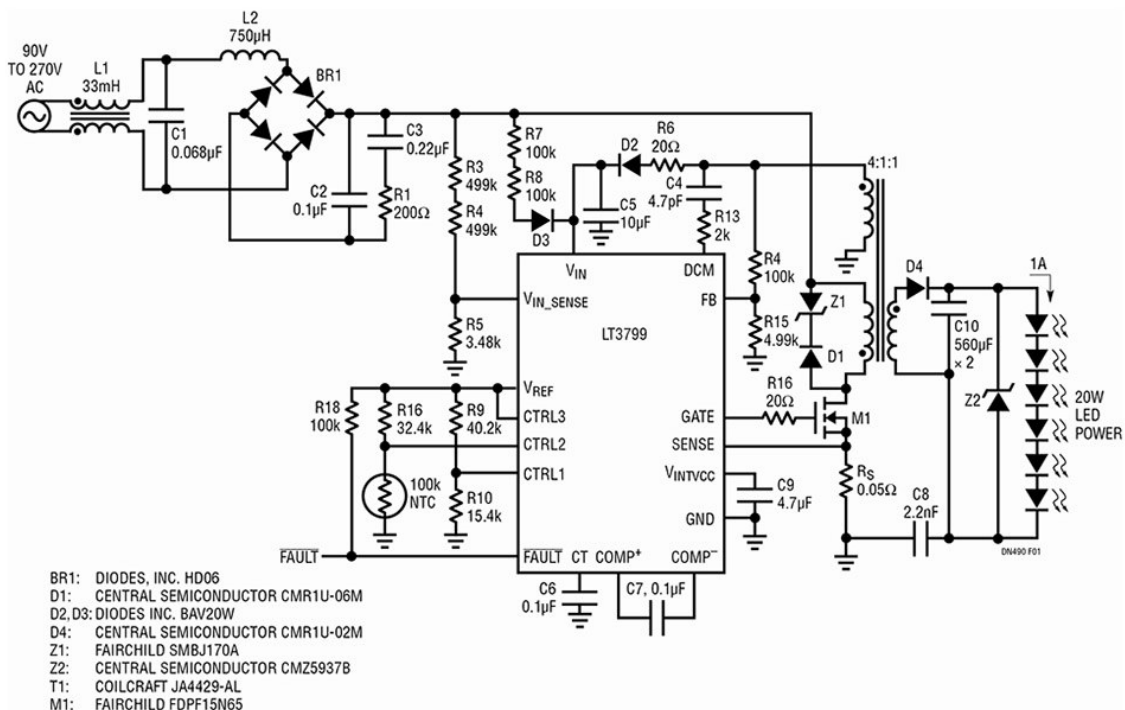

1. What is the energy efficacy (lumens per Watt) of an LED light bulb? Why are LED bulbs becoming popular in Jordan and worldwide?

2. Look around you in the Lab. What type of light source is used in the lab? Why?

.....







3. List two reasons why the fluorescent lamps require a ballast to work properly?

.....

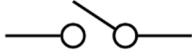
PROCEDURE C - SWITCH CONTROL OF LIGHTING CIRCUITS

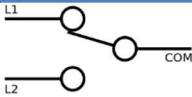
Switches are used to turns lights and other appliances on and off. Table 5 summarizes the most popular switch types for home wiring.

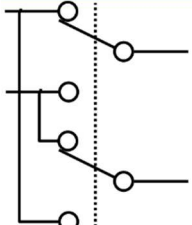
Table 5

Abbrevia- tion ‡	Expansion of abbreviation ‡	American electrical wiring name ‡	Symbol ‡	Example
SPST	Single pole, single throw	Single-pole switch		
SPDT	Single pole, double throw	Three-way switch		
DPCO	Double pole changeover	Four-way switch		

‡ Students should expect to be asked in the final exam about information in the columns of this table that are designated by this marker.

The Figure below shows how to control a lamp with a single-pole switch if the source is fed at the switch (i.e., the source wires enter at the switch box). This is a simple ON/OFF switch connection. Notice that the black grounded conductor is spliced directly through to the lamp. The red conductor from the supply circuit connects to one terminal on the switch. The red conductor in the cable coming from the outlet box at the lamp is connected to the other terminal on the switch. Because a single-pole switch connection is simply a series circuit, it makes no difference which terminal is the supply and which terminal is the load. This layout supplies a neutral conductor (black wire) at the switch. That is why many electricians prefer to run the feed to the switch then up to the light.

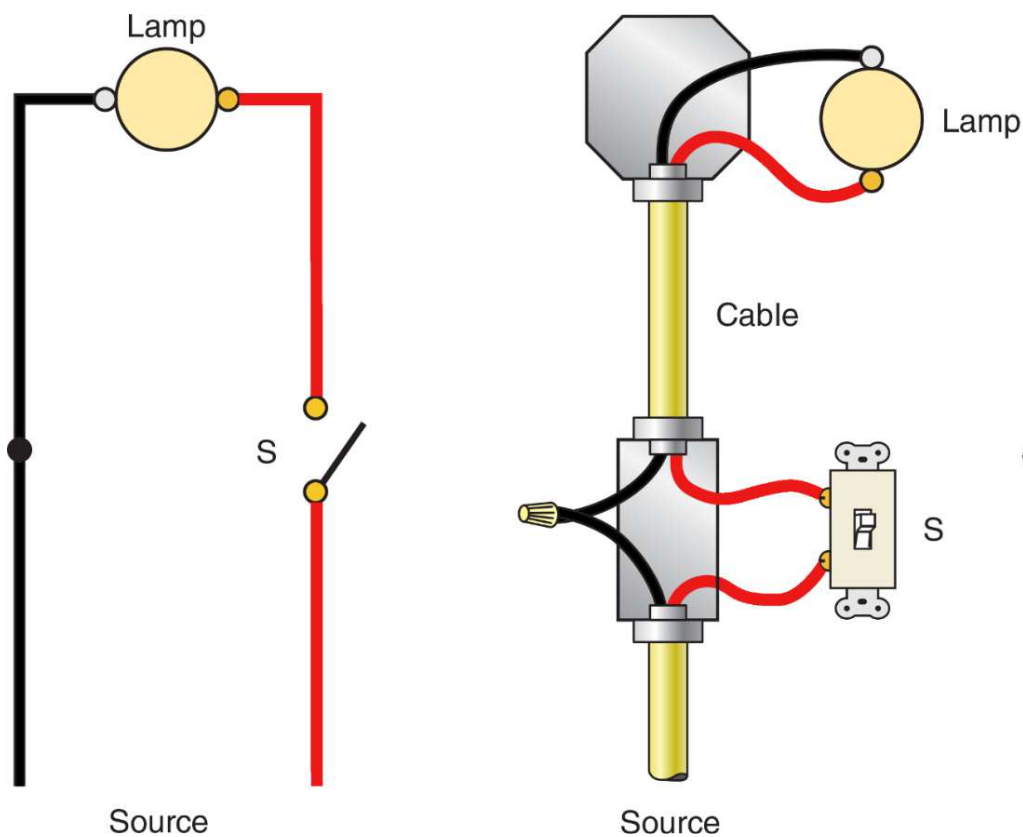

The Figure below shows the AC source entering the outlet box where the luminaire will be connected. If a cable is used as the wiring method, a 3-wire cable is preferred. The conductor with blue insulation is the supply to the switch and the conductor with red insulation is the return conductor. The conductor with black insulation is the neutral and is sent to the switch box so that an electronic switch, such as an occupancy sensor or timer, can be connected properly.

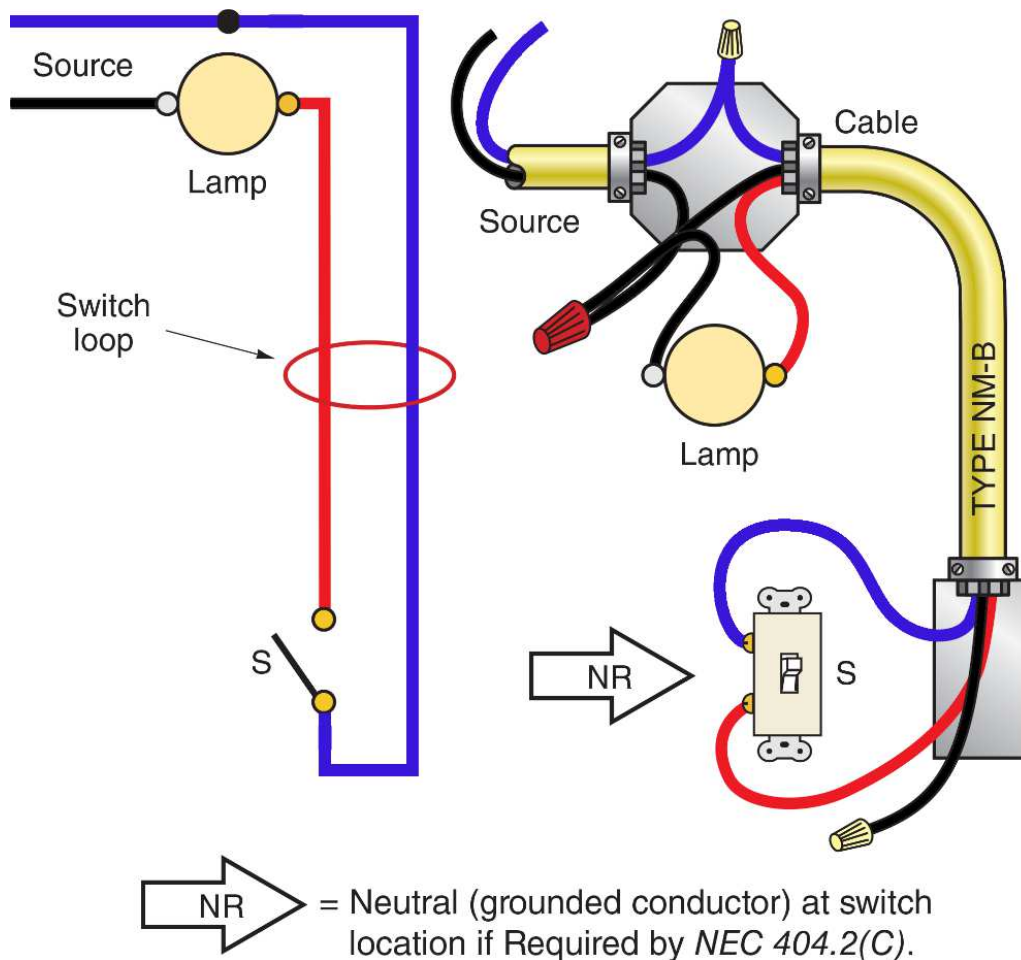

Finally, the following figure shows two three-way switches controlling one light, such as in different locations of the room, or on a stairway. The source enters at the outlet box. The black conductor from the 220-volt source at the outlet box is connected to the neutral that is required at both switch boxes and to a jumper for the luminaire. A 4-wire cable is run to both switch boxes. From the outlet box to the switch on the left, the blue conductor in the 4-wire cable serves as the switch return to the lamp, and the red conductor and the green conductor are the travelers. From the outlet box to the switch on the right, the blue conductor serves as the supply to the 3-way switch, and the red conductor and the green conductor are the travelers. For uniformity, the conductor with red insulation and the conductor with green insulation used for travelers are identified and connected in the outlet box.

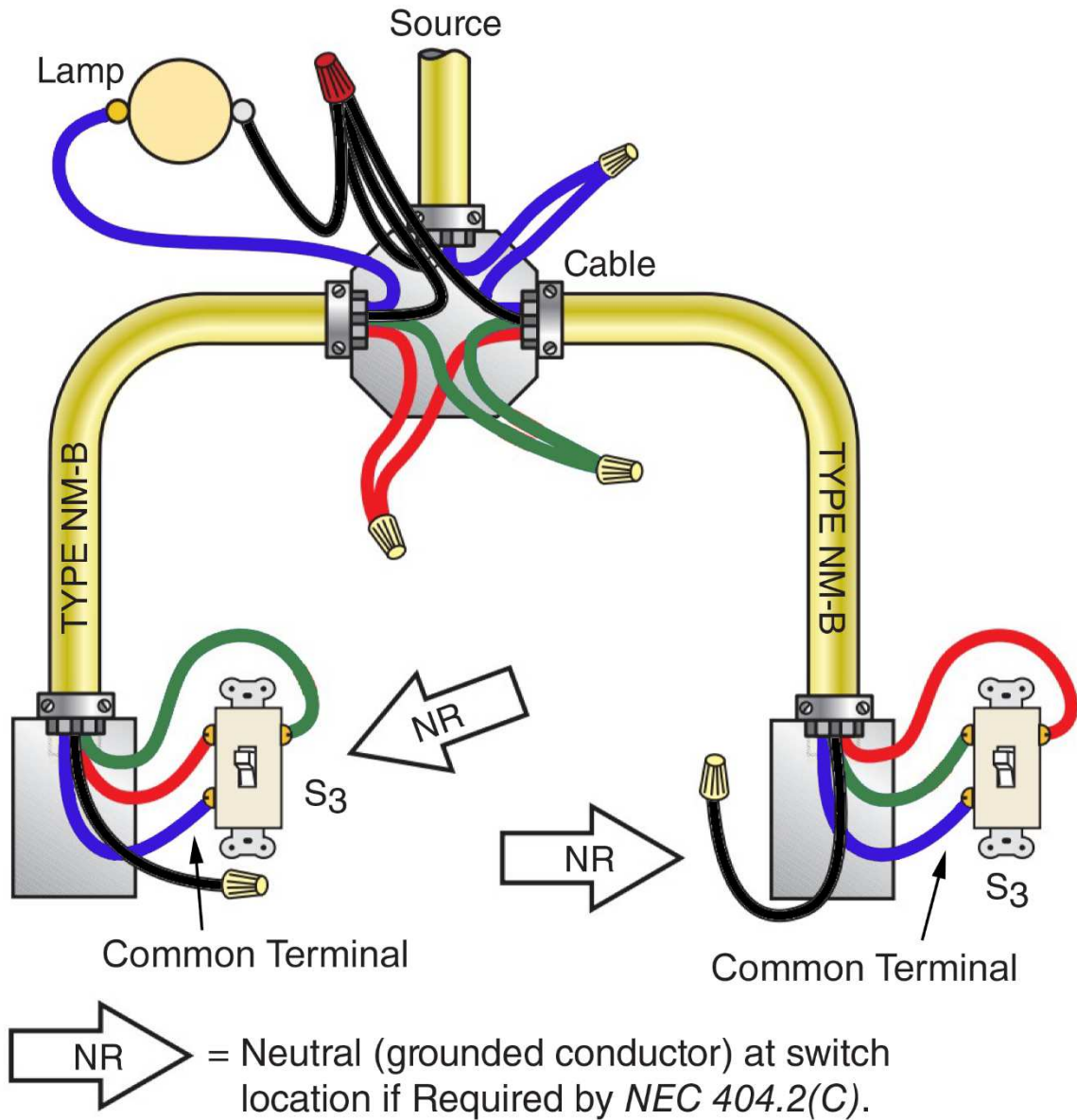

1. To understand the above diagram, re-draw it as a schematic in the space provided below. Notice that the bulb is considered as a resistive load.

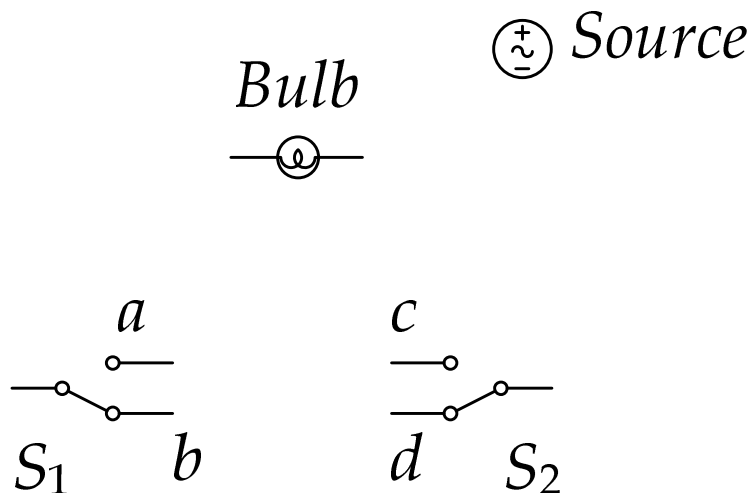

2. Use the breadboard and the provided 5V light bulb and three-way switches to connect the circuit you designed above. Use a function generator (set to 5 V_{rms} and 50 Hz) to simulate the mains supply.

3. Which positions of the switches S1 and S2 above result in the light switching ON?

.....

4. Which type of switch do you think will be helpful to allow three switches to control one light on a stairway?

.....

PROCEDURE D - SAFETY AND PROTECTION

An electric shock can cause considerably more damage to the human body than is visible. A person may suffer internal hemorrhages, destruction of tissues, nerves, and muscles. Further injury can result from a fall, cuts, burns, or broken bones due to a reflex, such as jumping or pulling back.

The effect of an electric current passing through a human body varies, depending on circuit characteristics, i.e., current, frequency [50/60 Hz is the worst], voltage, body contact resistance [open wounds are extremely hazardous as compared to a callused hand], internal body resistance, the path of current, duration of contact, and environmental conditions (e.g., humidity).

The contact resistance of a typical body can vary from a few hundred ohms to many thousand ohms. Let's see how important the role of resistance is for a person coming in contact with a 220-volt circuit. Take a dry hand, for example, which has a resistance of 100 kΩ:

$$I = \frac{V}{R} = \frac{220 V}{100 k\Omega} = 2.2 mA$$

This would probably be a little tingle. Now take a wet hand and standing barefoot on the ground:

$$I = \frac{V}{R} = \frac{220V}{1 k\Omega} = 220 mA$$

This would probably be fatal.

Table 6 shows expected sensations at various current levels in milliamperes. The path of current is very important. Where and how is contact to the live conductor made? What are you touching with the other hand? Where and in what are you standing? The current flow might be finger to finger, hand to hand, head to hand, head to foot, or any other combination. Hand to foot can be fatal because the current is probably passing through the heart and lungs.

Table 6

Effect	Current @ 60 Hertz	
	Men	Women
Cannot be felt	0.4 mA	0.3 mA
A little tingling – mild sensation	1.1 mA	0.7 mA
Shock – not painful – can still let go	1.8 mA	1.2 mA
Shock – painful – can still let go	9.0 mA	6.0 mA
Shock – painful – just about the point where you can't let go – called "threshold" – may be thrown clear ‡	16.0 mA ‡	10.5 mA ‡
Shock – painful – severe – can't let go – muscles immobilized – breathing stops ‡	23.0 mA ‡	15.0 mA ‡
Ventricular fibrillation (usually fatal)		
Length of time: 0.03 seconds	1000 mA	1000 mA
Length of time: 3.0 seconds	100 mA	100 mA

‡ Students should expect to be asked about values designated by this marker in the final exam.

Generally, voltages of less than 50 volts to ground are considered safe. Voltages 50 volts and greater are considered lethal. All AC systems (with few exceptions) of 50 volts to 1000 volts that supply premises wiring are required to be grounded.

Three electrical devices can help keep you safe at home: fuses, circuit breakers, and GFCI (Ground-fault Circuit Interrupter) receptacles. A fuse (see below) is a low resistance wire or strip that provides overcurrent protection by melting down when too much current flows through it, interrupting the circuit that it connects.

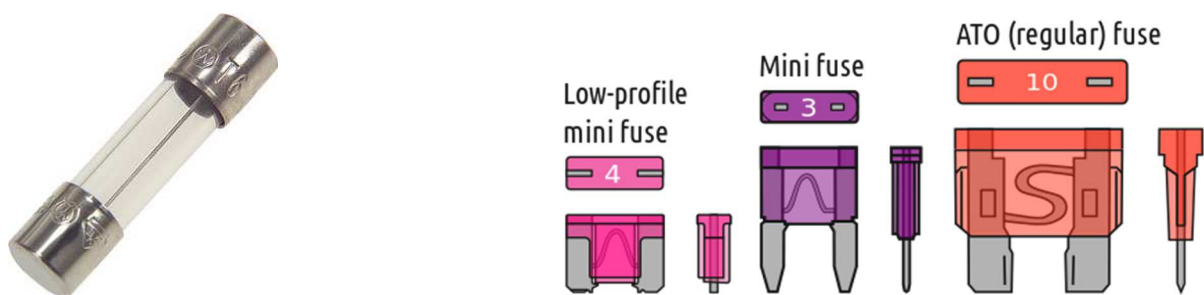

A circuit breaker switch is designed to detect high current and if so interrupt the circuit. Unlike a fuse, which operates once and then must be replaced, a circuit breaker can be reset to resume normal operation. Below are some examples of circuit breakers. Notice the current rating on each of these circuit breakers.



Circuit breaks are built in different ways. For example, magnetic circuit breakers use a solenoid (electromagnet) whose pulling force increases with the current, while thermal magnetic circuit breakers, which are the type found in most distribution boards, incorporate two techniques: an electromagnet responding instantaneously to large surges in current (short circuits) and a bimetallic strip that bends downward with extra heating from high current, thus releasing a spring-loaded trip-lever. Since heating is fairly slow, the bimetallic strip responds to less extreme but longer-term over-current conditions.

Finally, a residual-current circuit breaker (RCCB), or a Ground Fault Circuit Interrupter (GFCI), disconnects a circuit whenever it detects that the electric current is not balanced between the energized (line) conductor and the return (neutral) conductor. In normal circumstances, these two wires are expected to carry matching currents, and any difference indicates a short circuit or a leakage current. A ground fault in the range of 4 to 6 mA or more typically trips the breaker circuit. GFCIs are usually testable and resettable devices (see figure below); they include a button that when pressed safely creates a small leakage condition, and a switch that reconnects the conductors when a fault condition has been cleared.



Notice, however, that a GFCI does not provide protection against dangerously high currents when the current is flowing in the usual wires in the circuit, therefore they cannot replace the need for a fuse or a circuit breaker.

1. What is the current limit after which humans start suffering severe injuries?

.....

2. Identify the circuit breakers in the Lab and your home. What is the current rating for some of these circuit breakers?

.....

3. Some people think that OFF switches are safe. This is wrong. To see that, determine the voltage between the two ends of the single-pole switch shown below (as measured by the voltmeter)? Hint: Treat the lamp as a resistor.

.....

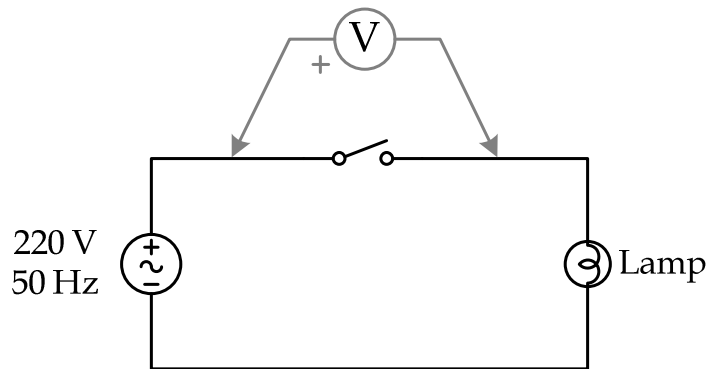

**** End ****